

CHAMBERLAIN®

LiftMaster®
PROFESSIONAL

The Chamberlain Group, Inc.
845 Larch Avenue
Elmhurst, Illinois 60126-1196
www.liftmaster.com



SECURITY+
DOOR OPERATOR
Model 3900PLD

*For Light Duty Commercial Use Install On
Sectional Doors With Torsion Assemblies Only*

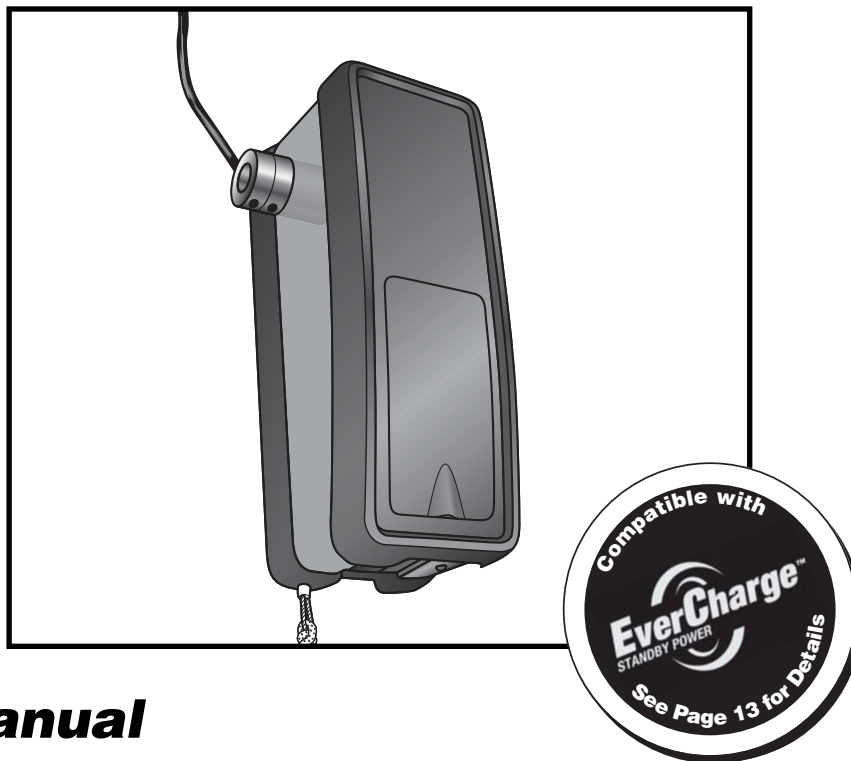

Owner's Manual

- Please read this manual and the enclosed safety materials carefully!
- Fasten the manual near the door after installation.
- The door **WILL NOT CLOSE** unless The Protector System® and cable tension monitor are connected and properly aligned.
- Periodic checks of the operator are required to ensure safe operation.
- The model number label is located behind the hinged door of your operator.
- Do **NOT** exceed 10 complete cycles of door operation per hour.

2 YEAR WARRANTY

Serial # _____
(located on electrical box cover)

Installation Date _____

TABLE OF CONTENTS

Introduction	2-5	Operation	21-25
Safety symbol review and signal word review	2	Operation safety instructions	21
Planning	3	Using your door operator	21
Preparing your door	4	Care of your operator	22
Tools needed	4	Having a problem? (Troubleshooting)	23-24
Specifications	4	Diagnostic Chart	25
Carton inventory	5	Programming	26-28
Hardware inventory	5	To add or reprogram a hand-held remote control (Not Provided)	26
Assembly	6	To erase all codes from motor unit memory	26
Attach the collar to the operator	6	3-Button remote	26
Attach mounting bracket to the operator	6	The remote control battery	26
Installation	7-16	To add, program or change a keyless entry PIN (Not Provided)	27
Installation safety instructions	7	Programming remote light (Not Provided)	28
Position the operator	7	Repair Parts	29
Attach the emergency release rope and handle	8	Installation parts	29
Install power door lock (Not Provided)	8	Motor unit assembly parts	29
Attach the cable tension monitor (Required)	9	Accessories	30
Install the single button control station	10	Notes	31
Install the light (Not Provided)	11	Repair Parts and Service	Back Page
Electrical requirements	12		
Mount the Standby Power Unit (SPU) (Not Provided)	13		
Install The Protector System®	14-16		
Adjustment	17-20		
Program the travel limits	17		
Setting the force	18		
Test the safety reversal system	19		
Test The Protector System®	19		
Test cable tension monitor	20		
To open door manually	20		

INTRODUCTION

Safety Symbol Review and Signal Word Review

This door operator has been designed and tested to offer safe service provided it is installed, operated, maintained and tested in strict accordance with the instructions and warnings contained in this manual.

 **WARNING**

Mechanical

 **WARNING**

Electrical

CAUTION

When you see these Safety Symbols and Signal Words on the following pages, they will alert you to the possibility of **serious injury or death** if you do not comply with the warnings that accompany them. The hazard may come from something mechanical or from electric shock. Read the warnings carefully.

When you see this Signal Word on the following pages, it will alert you to the possibility of damage to your garage door and/or the garage door operator if you do not comply with the cautionary statements that accompany it. Read them carefully.

Planning

Survey your area to see if any of the conditions below apply to your installation. Additional materials may be required. You may find it helpful to refer back to this page as you proceed with the installation of your operator.

Depending on your requirements, there are several installation steps which may call for materials or hardware not included in the carton.

This operator is compatible with:

- Doors that use a torsion bar, springs and a door no more than 14' (4.2 m) high.
- 4"-6" (10 cm - 15 cm) drums, not to be used on tapered drums over 6" (15 cm).
- High lift and standard lift sectional doors up to 14' (4.2 m) high.
- Doors up to 18' (5.4 m) wide.
- Doors up to 180 sq. ft. (16.7 sq. m).
- 1" (2.5 cm) torsion bar only.
- Review or inspect proposed installation area. Operator can be installed on left or right side of door. Select the side that meets the requirements listed below.
 - Must have minimum of 2-1/2" (6.4 cm) between the wall and the center of the torsion bar.
 - Must have minimum of 3" (7.6 cm) between the ceiling and the center of torsion bar.
 - Must have minimum of 8" (20.3 cm) between the side wall (or obstruction) and the end of torsion bar.

- The torsion bar must extend at least 1" to 5" (2.5 cm to 12 cm) past the bearing plate.
- An electric outlet is required within 6' (1.8 m) of the installation area. If outlet does not exist, contact a qualified electrician.
- Depending upon building construction, extension brackets or wood blocks may be needed to install safety reversing sensors.
- Alternate floor mounting of the safety reversing sensors will require hardware not provided.
- A model 475LM EverCharge™ Standby Power Unit is strongly recommended if there is no access door to the garage, as this operator cannot be used in conjunction with an external emergency release mechanism.
- Any gap between the floor and the bottom of the door must not exceed 1/4" (6 mm). Otherwise the safety reversal system may not work properly.

NOTE: *Inspect the torsion bar while the door is raised and lowered. It is important that there is no noticeable movement up and down or left and right. If this type of movement is not corrected, life of this operator will be greatly reduced.*

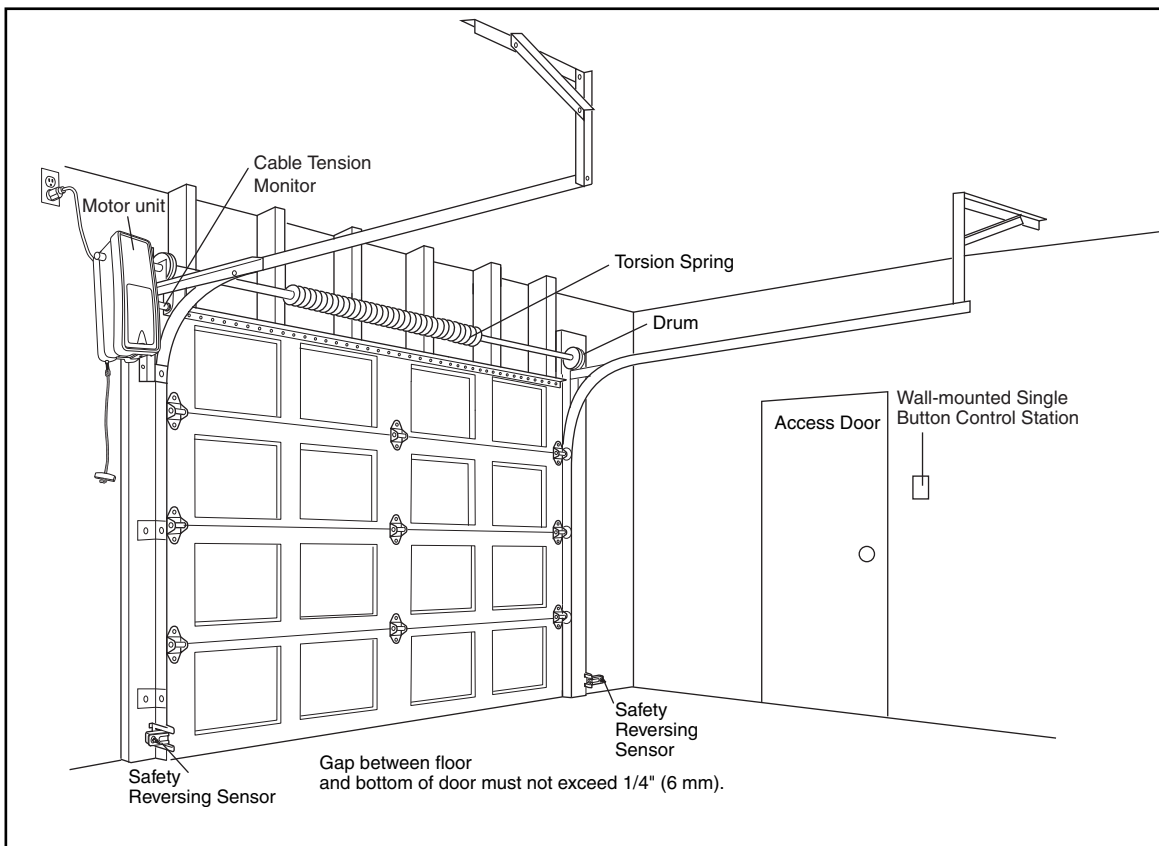

Preparing your Door

Before you begin:

- Disable locks.
- Remove any ropes connected to door.
- **Complete the following test** to make sure your door is balanced and is not sticking or binding:

1. Lift the door about halfway as shown. Release the door. If balanced, it should stay in place, supported entirely by its springs.
2. Raise and lower the door to see if there is any binding or sticking.

If your door binds, sticks or is out of balance, call a trained door systems technician.

3. Verify equal cable tension on each side of door. Cable tension should remain equal during the entire travel of the door.

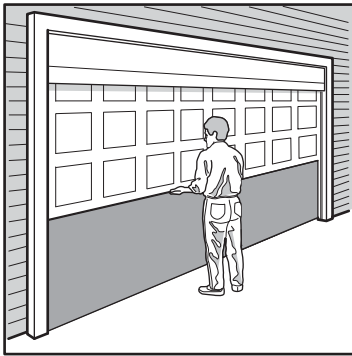

Sectional Door

Tools needed

During assembly, installation and adjustment of the operator, instructions will call for hand tools as illustrated below.

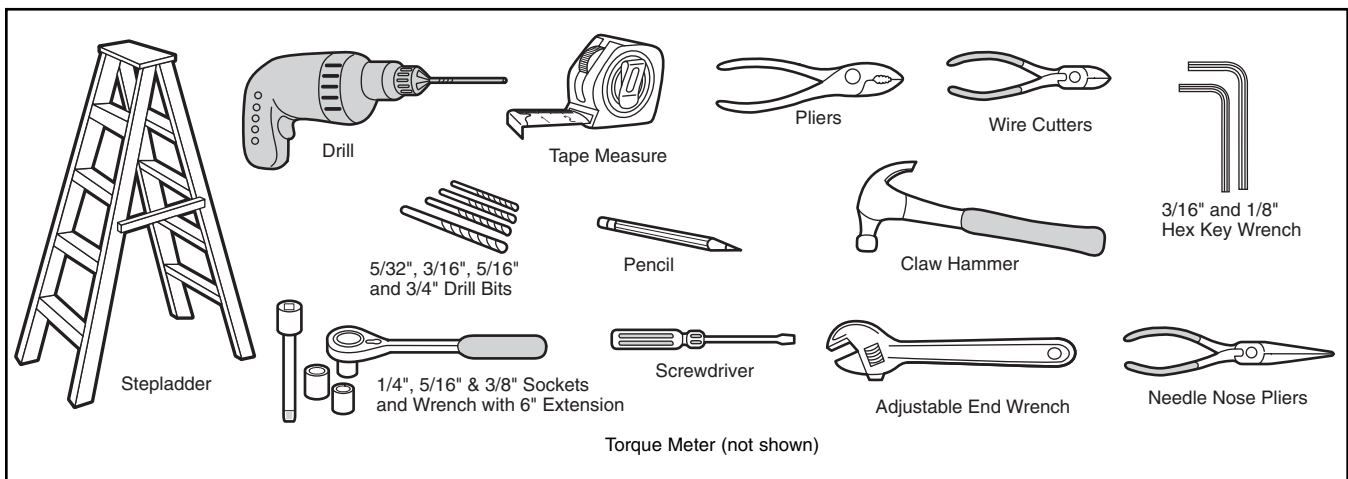

WARNING

To prevent possible **SERIOUS INJURY** or **DEATH**:

- **ALWAYS** call a trained door systems technician if door binds, sticks or is out of balance. An unbalanced door may not reverse when required.
- **NEVER** try to loosen, move or adjust door, door springs, cables, pulleys, brackets or their hardware, **ALL** of which are under **EXTREME** tension.
- Disable **ALL** locks and remove **ALL** ropes connected to door **BEFORE** installing and operating door operator to avoid entanglement.

CAUTION

To prevent damage to door and operator:

- **ALWAYS** disable locks **BEFORE** installing and operating the operator.
- **ONLY** operate door operator at 120V, 60 Hz to avoid malfunction and damage.
- Do **NOT** exceed 10 complete cycles of door operation per hour.

Specifications

Volts 120 Vac - 60 Hz, **ONLY**
 Current 1.0 AMP
 Rated Load 325 in.lb/sec
 10 Cycles per Hour

Carton Inventory

Your door operator is packaged in one carton which contains the motor unit and the parts illustrated below.

Note that accessories will depend on the model purchased. If anything is missing, carefully check the packing material.

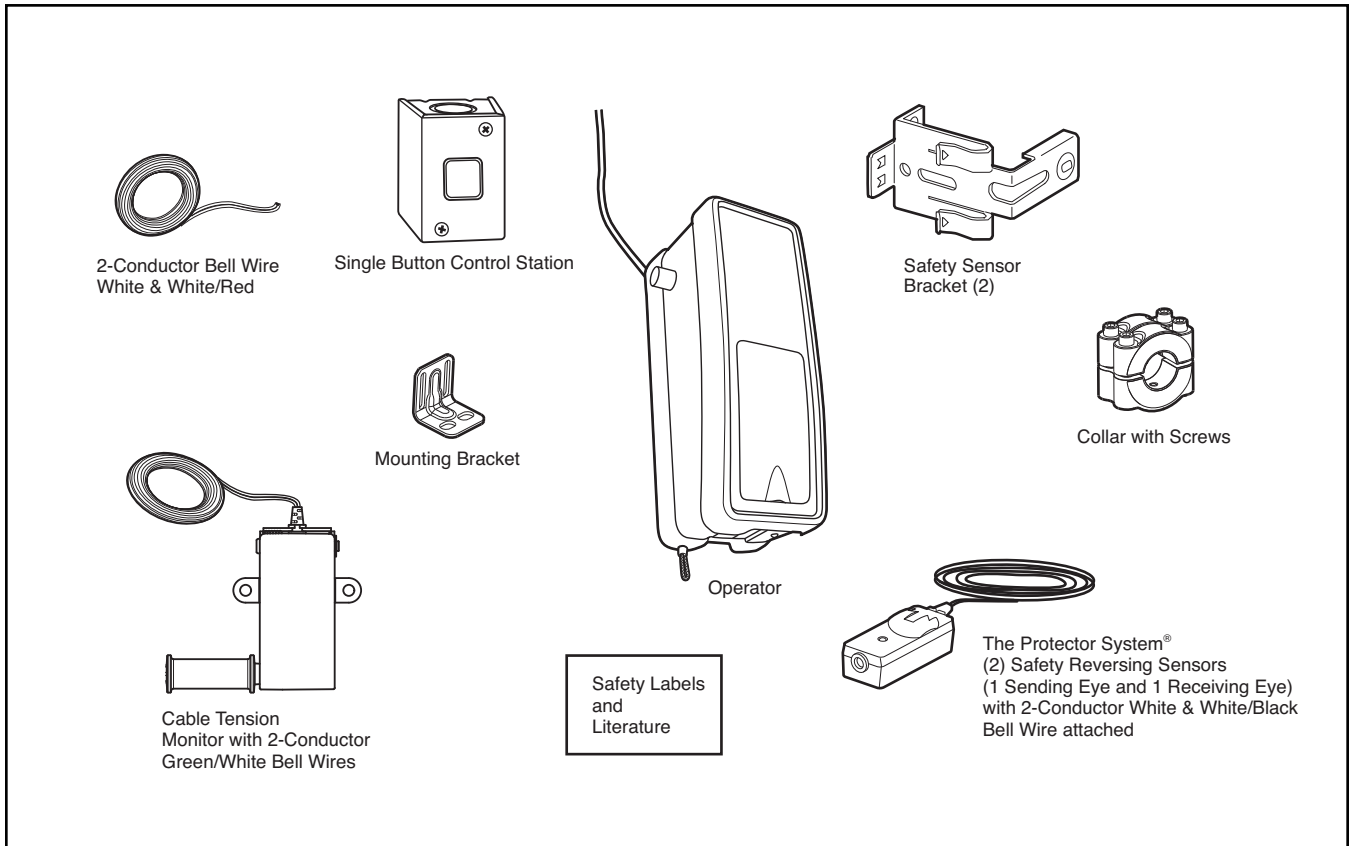

Hardware Inventory

INSTALLATION HARDWARE

Hex Screw #14-10x1-7/8" (4)

Screw #6x-1-1/4" (2)

Machine Screw #6x1" (2)

Carriage Bolt 1/4"-20x1/2" (2)

Wing Nut 1/4"-20 (2)

Pan Head Screw 1/4"-20x1/2" (2)

Hex Head Screw #8x1" (2)

Self Tapping Screw #10-32 (2)

Drywall Anchor (2)

Drywall Anchor (Screw-In) (2)

Handle

Rope

Insulated Staples (30)

ASSEMBLY STEP 1

Attach the Collar to the Operator

To avoid installation difficulties, do not run the door operator until instructed to do so.

- Loosen the collar screws.
- Attach collar to either the left or the right side of the operator. Ensure that the collar is seated all the way on motor shaft until stop is reached (Figure 1).
- Position the collar so that the screws are facing up (accessible when attached to the torsion bar).
- Tighten both sides of collar screws equally to secure collar to the motor unit (12-14 ft./lbs. of torque) (Figure 2).

NOTE: For most installations the screws should be facing up for easy access. Do not tighten set screws until indicated.

ASSEMBLY STEP 2

Attach Mounting Bracket to the Operator

- Loosely attach slotted side of mounting bracket to the same side of the operator as the collar, using self-threading screws provided.

NOTE: Do not tighten until instructed. Illustrations shown are for left side installation.

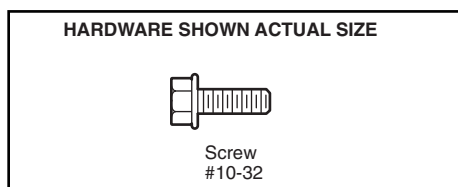

⚠ WARNING

To prevent possible **SERIOUS INJURY** or **DEATH**, the collar **MUST** be properly tightened. The door may not reverse correctly or limits may be lost due to collar slip.

Figure 1

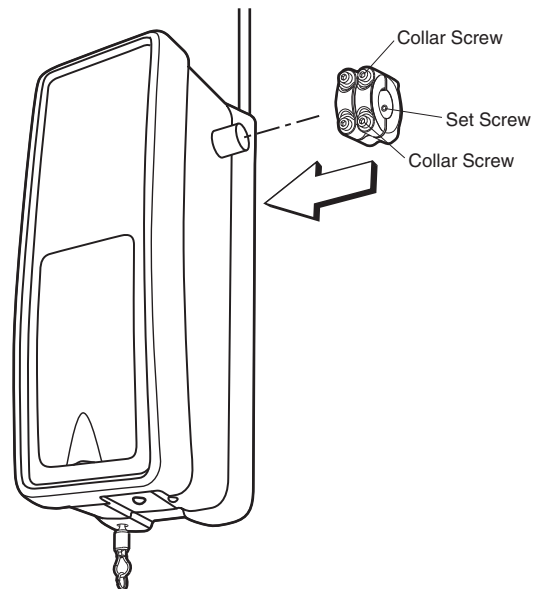
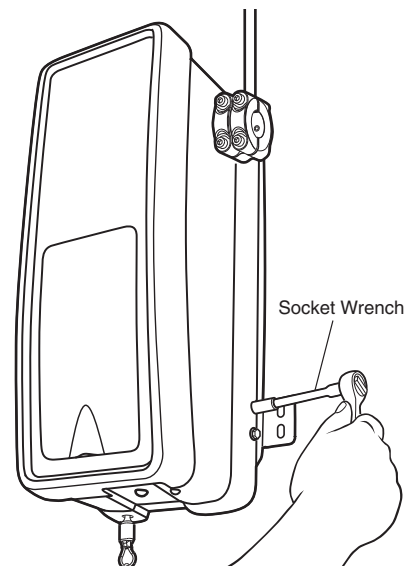
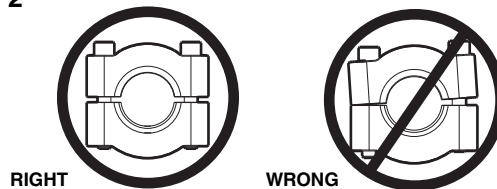

Figure 2



INSTALLATION

IMPORTANT INSTALLATION INSTRUCTIONS

WARNING

To reduce the risk of SEVERE INJURY or DEATH:

1. READ AND FOLLOW ALL INSTALLATION WARNINGS AND INSTRUCTIONS.
2. Install door operator ONLY on properly balanced and lubricated door. An improperly balanced door may not reverse when required and could result in SEVERE INJURY or DEATH.
3. ALL repairs to cables, spring assemblies and other hardware MUST be made by a trained door systems technician BEFORE installing operator.
4. Disable ALL locks and remove ALL ropes connected to door BEFORE installing operator to avoid entanglement.
5. Mount emergency release handle no higher than 6 feet (1.83 m) above floor.
6. NEVER connect door operator to power source until instructed to do so.
7. NEVER wear watches, rings or loose clothing while installing or servicing operator. They could be caught in door or operator mechanisms.
8. Install wall-mounted door control:
 - within sight of the door.
 - out of reach of children at minimum height of 5 feet (1.5 m).
 - away from ALL moving parts of the door.
9. Place entrapment warning label on wall next to door control.
10. Place manual release/safety reverse test label in plain view on inside of door.
11. Upon completion of installation, test safety reversal system. Door MUST reverse on contact with a 1-1/2" (3.8 cm) high object (or a 2x4 laid flat) on the floor.

INSTALLATION STEP 1

Position the Operator

NOTE: For additional mounting options see accessories page.

1. Close the door completely.
2. Slide the operator with collar over the end of the torsion bar. Ensure that the collar does not touch the bearing plate. Check to make sure the mounting bracket is located on a solid surface such as wood, concrete or door/flag bracket. Snug collar screws to help assure proper alignment of operator. Mark the bracket holes. It may be necessary to cut the torsion bar if it is too long or damaged.
3. Loosen collar screws from torsion bar and remove the operator. Drill 3/16" pilot holes at the marked locations. Drill through steel plate if needed.
4. Reinstall the operator by sliding the collar over the torsion bar until pilot holes align with bracket. Securely tighten collar screws that attach to the torsion bar to 12-14 ft./lbs. of torque. Securely tighten both set screws firmly, without damaging the motor unit.
5. Fasten bracket securely with 14-10x1-7/8" screws. Tighten all mounting bracket hardware.

NOTE: The motor unit does not have to be flush to wall.

6. Use a staple to secure the antenna wire to prevent antenna from being entangled in a door roller.

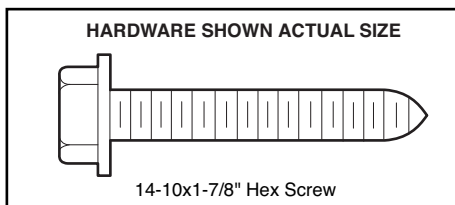

WARNING

To prevent possible SERIOUS INJURY or DEATH:

- Concrete anchors MUST be used if mounting bracket into masonry.
- NEVER try to loosen, move or adjust door, springs, cables, pulleys, brackets or their hardware, ALL of which are under EXTREME tension.
- ALWAYS call a trained door systems technician if door binds, sticks or is out of balance. An unbalanced door might not reverse when required.
- Operator MUST be mounted at a right angle to the torsion bar to avoid premature wear on the collar.

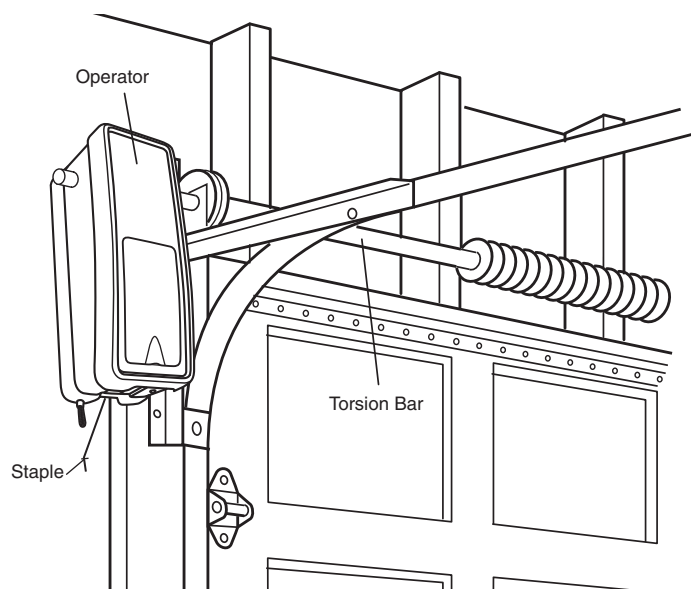

INSTALLATION STEP 2

Attach the Emergency Release Rope and Handle

- Thread one end of the rope through the hole in the top of the red handle so "NOTICE" reads right side up as shown. Secure with an overhand knot at least 1" (2.5 cm) from the end of the rope to prevent slipping.
- Thread the other end of the rope through the loop in the emergency release cable.
- Adjust rope length so the handle is no higher than 6' (1.83 m) above the floor. Secure with an overhand knot.

NOTE: If it is necessary to cut the rope, heat seal the cut end with a match or lighter to prevent unraveling.

! WARNING

To prevent possible SERIOUS INJURY or DEATH from a falling door:

- If possible, use emergency release handle to disengage door ONLY when door is CLOSED. Weak or broken springs or unbalanced door could result in an open door falling rapidly and/or unexpectedly.
- NEVER use emergency release handle unless doorway is clear of persons and obstructions.

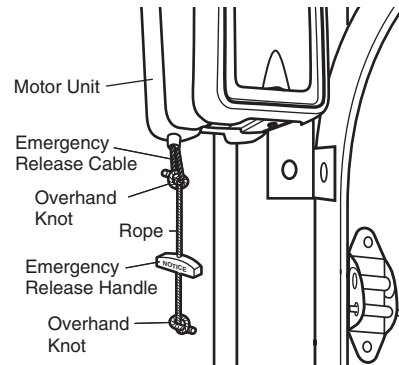

INSTALLATION STEP 3

Install Power Door Lock (Not Provided)

The lock is used to prevent the door from being manually opened once the door is fully closed.

1. Select a door roller to mount the lock above. Check for clearance. If possible select a roller on the same side of the door as the motor unit. The second roller up from the bottom is ideal in most installations.
2. Ensure rail surface is clean and adhere lock template to achieve a 3" (7.6 cm) distance between the center of the roller and the pin hole (Figure 1).
3. Drill holes as marked on the template.
4. Fasten power door lock to the outside of the garage door track with hardware provided.
5. Run bell wire up wall to motor unit. Use insulated staples to secure wire in several places.
6. Plug connector into the motor unit (Figure 2).

NOTE: Lock must be mounted within 10' of the power head.

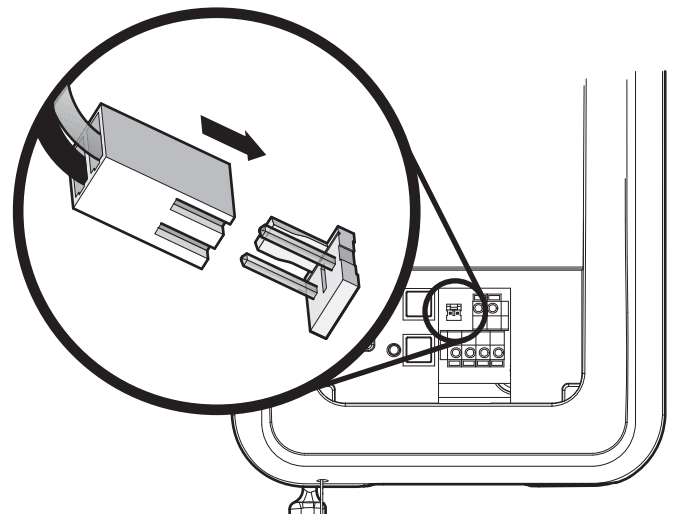
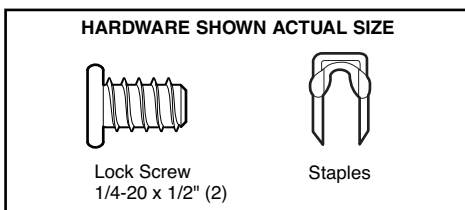
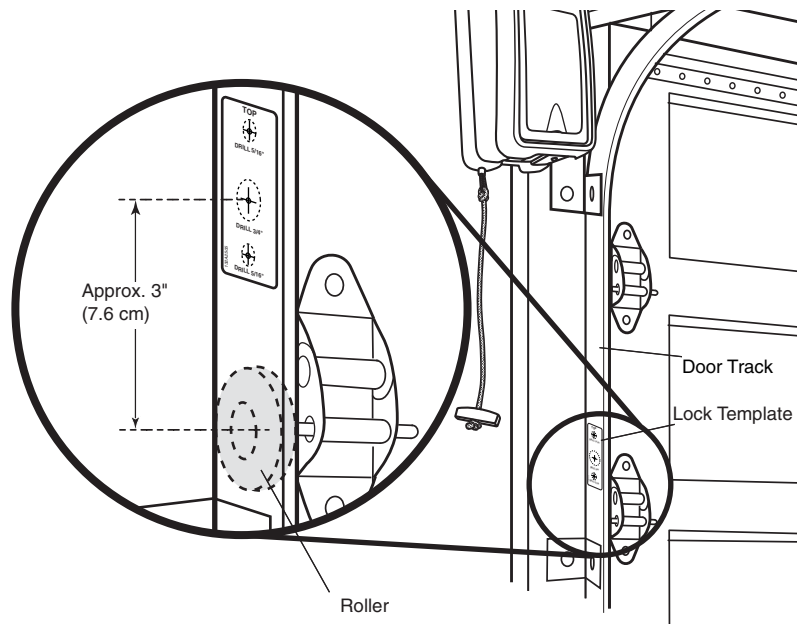

INSTALLATION STEP 4

Attach the Cable Tension Monitor (Required)

This operator comes standard with the cable tension monitor. It is supplied as a device to monitor the cables for ANY slack that may occur and will reverse the door when excessive slack is detected, eliminating service calls.

The cable tension monitor **MUST** be connected and properly installed before the door operator will move in the down direction.

NOTE: The cable tension monitor is shipped for left side installation. It is preferred that the cable tension monitor be installed on the same side of the door as the operator. If required, it can be mounted on the opposite side of door. Remove the snap-ring holding the roller in place and reassemble it on the opposite side of the cable tension monitor.

1. Position the cable tension monitor as shown (Figures 1 and 2). The cable tension monitor should be located as close to the drum as possible.

NOTE: There must be no obstructions in the installation area that prevent the cable tension monitor or the cable itself from closing completely when slack is detected.

2. Make sure cable tension monitor is located over a wood support member.

NOTE: If the cable tension monitor can not be mounted into wood with the lag screws provided, it can be mounted into 1/2" or greater drywall using the wall anchors (2) and the #8 hex head screws (2) provided in the hardware bag.

3. Mark and drill 3/16" pilot holes for screws (pilot holes are not required for anchors).
4. Attach the cable tension monitor to the wall using the hardware provided. Make sure that the roller is on top of the cable.
5. Run bell wire to operator. Use insulated staples to secure wire in several places.
6. Connect bell wire to the green quick-connect terminals (polarity is not important) (Figure 3).

NOTE: Cable must have tension through entire travel. Make sure there is no slack in cable on opposite side of door during normal operation. If this condition exists, adjust cables as required.

Figure 1

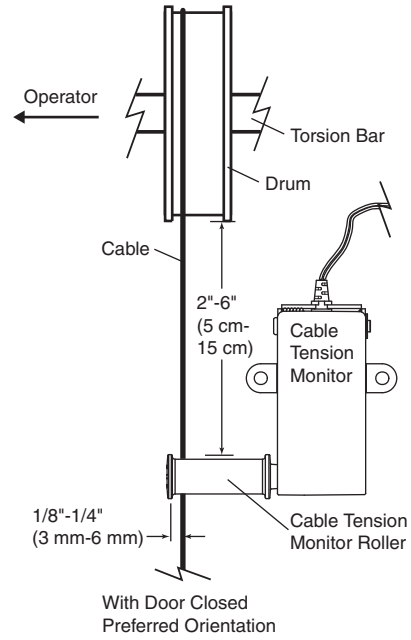

Figure 2

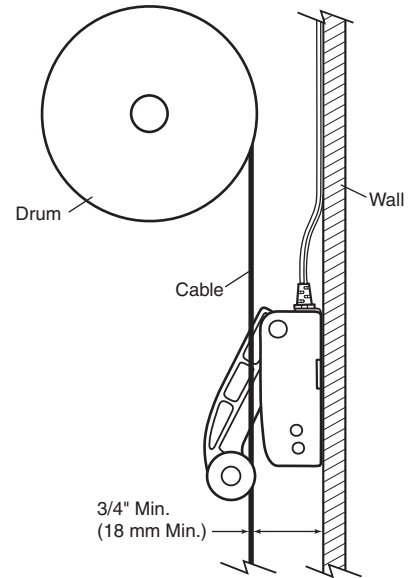
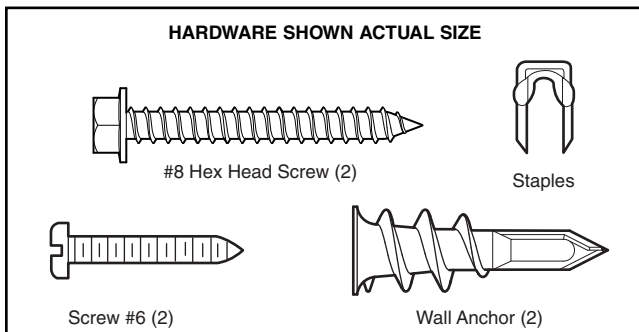
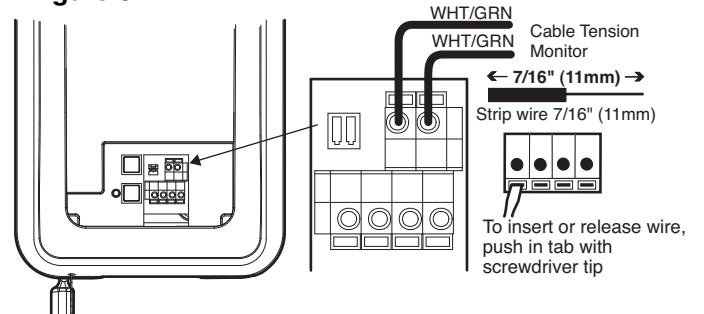

Figure 3



INSTALLATION STEP 5

Install the Single Button Control Station

WARNING

To prevent possible SERIOUS INJURY or DEATH from electrocution:

- Be sure power is not connected BEFORE installing door control.
- Connect ONLY to 24 VOLT low voltage wires.

To prevent possible SERIOUS INJURY or DEATH from a closing door:

- Install door control within sight of door, out of reach of children at a minimum height of 5 feet (1.5 m) and away from ALL moving parts of door.
- NEVER permit children to operate or play with door control push buttons or remote controls.
- Activate door ONLY when it can be seen clearly, is properly adjusted and there are no obstructions to door travel.
- ALWAYS keep door in sight until completely closed. NEVER permit anyone to cross path of closing door.

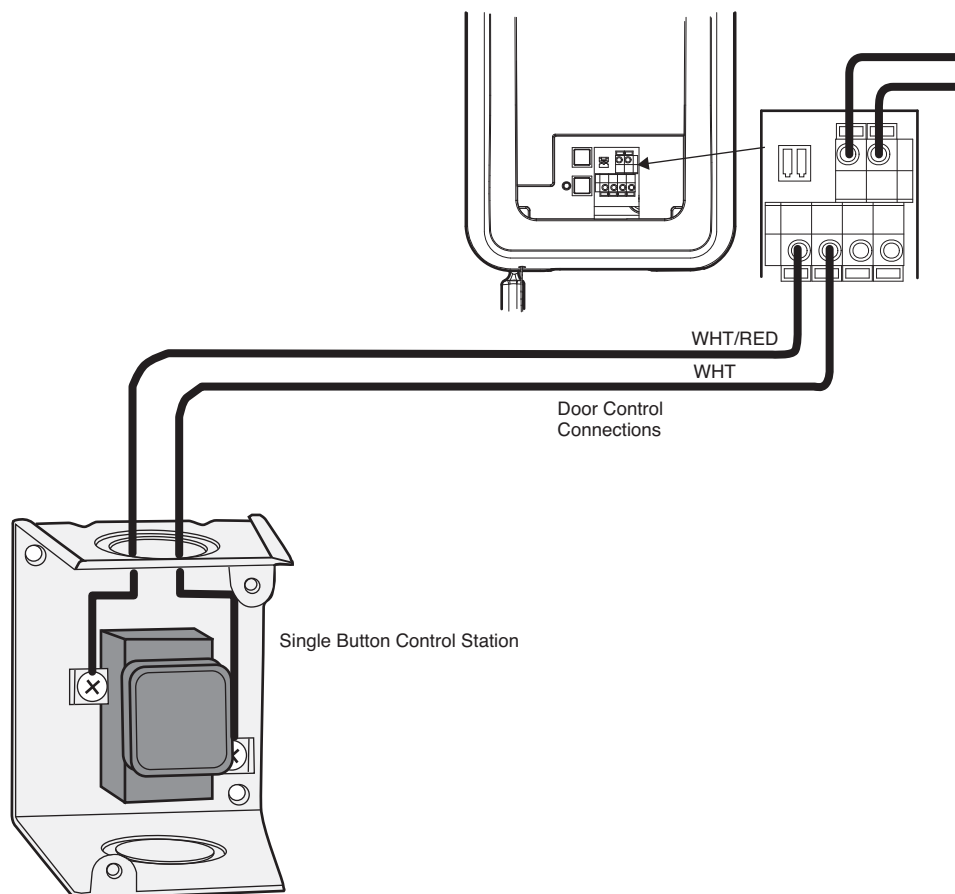

IMPORTANT SAFETY INSTRUCTIONS

WARNING

To reduce the risk of SEVERE INJURY or DEATH:

1. This portable luminaire has a polarized plug (one blade is wider than the other) as a feature to reduce the risk of electric shock.
2. This plug will fit in a polarized outlet ONLY one way.
3. If the plug does not fit fully in the outlet, reverse the plug.
4. If it still does not fit, contact a qualified electrician.
5. NEVER use with an extension cord unless plug can be fully inserted.
6. Do not alter the plug.
7. Light is intended for ceiling mount and indoor applications ONLY.

INSTALLATION STEP 6

Install the Light (Not Provided)

The remote light (operator light) is designed to plug directly into a standard 120V outlet.

1. Install the hinge and latch clips. Clips slide in between the metal plate and the plastic housing on each side of the light base (Figure 1).
2. Select an appropriate location on the ceiling to mount the light within 6' (1.8 m) of an electrical outlet so that the cord and light are away from moving parts.
3. Install the ceiling mount plate with the screws provided. Leave 1/8" (3.1 mm) of the thread exposed between the ceiling and the screw head (Figure 2).

NOTE: If installing remote light (operator light) on drywall and a ceiling joist can not be located, use wall anchors provided. No pilot hole is required for wall anchors.

4. Determine the length of power cord needed to reach the nearest outlet. Wind any excess cord around cord retainer on the top side of the light base.
5. Install the light base by pushing onto the screws and turning the base clockwise to lock the light in place.
6. Install two Type A19 incandescent or compact fluorescent bulbs. 100 watt maximum per bulb, 200 watts total.
7. Install the light lens by hooking one end of the lens over the hinge and pressing up on the other end to latch into place (Figure 3).
8. Plug in the light to outlet.
9. Light must be programmed to operate. See *Programming Remote Light*.

NOTE: Light will not operate until the unit is activated.

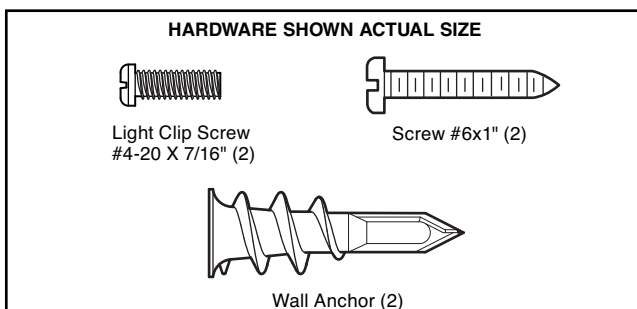

CAUTION

To prevent possible OVERHEATING of the endpanel or light socket:

- DO NOT use short neck or specialty light bulbs.
- DO NOT use halogen bulbs. Use ONLY incandescent.

To prevent damage to the operator:

- DO NOT use bulbs larger than 100W.
- ONLY use A19 size bulbs.

Figure 1

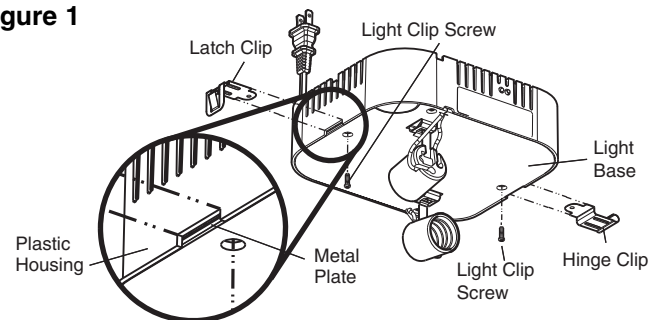

Figure 2

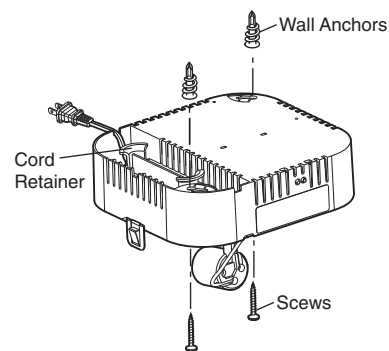
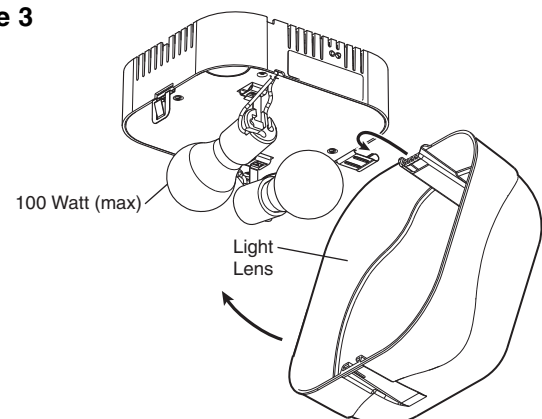

Figure 3



INSTALLATION STEP 7

Electrical Requirements

To avoid installation difficulties, do not run the operator at this time.

To reduce the risk of electric shock, your operator has a grounding type plug with a third grounding pin. This plug will only fit into a grounding type outlet. If the plug doesn't fit into the outlet you have, contact a qualified electrician to install the proper outlet.

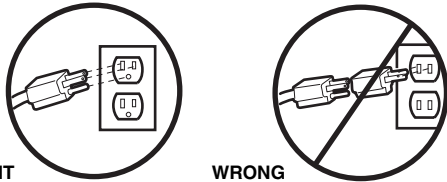

RIGHT

WRONG

If permanent wiring is required by your local code, refer to the following procedure.

To make a permanent connection through the 7/8" hole in the back of the operator (according to local code):

- Remove the operator from the torsion bar, remove cover screws and set the cover aside.
- Remove the attached green ground terminal.
- Cut black and white wires and strip away 1/2" (1.3 cm) of insulation, 3" (7.6 cm) before spade terminals.
- Remove the power cord from unit.
- Install a 90° conduit or flex cable adapter to the 7/8" hole. Reinstall operator to torsion bar.
- Run wires through conduit, cut to proper length and strip insulation.
- Attach with wire nuts provided.
- Properly secure wire under plastic ties so that wire does not come in contact with moving parts.
- Reinstall the cover.

To avoid installation difficulties, do not run the operator at this time.

WARNING

To prevent possible SERIOUS INJURY or DEATH from electrocution or fire:

- Be sure power is not connected to the operator, and disconnect power to circuit BEFORE removing cover to establish permanent wiring connection.
- Door installation and wiring MUST be in compliance with ALL local electrical and building codes.
- NEVER use an extension cord, 2-wire adapter or change plug in any way to make it fit outlet. Be sure the operator is grounded.

PERMANENT WIRING CONNECTION

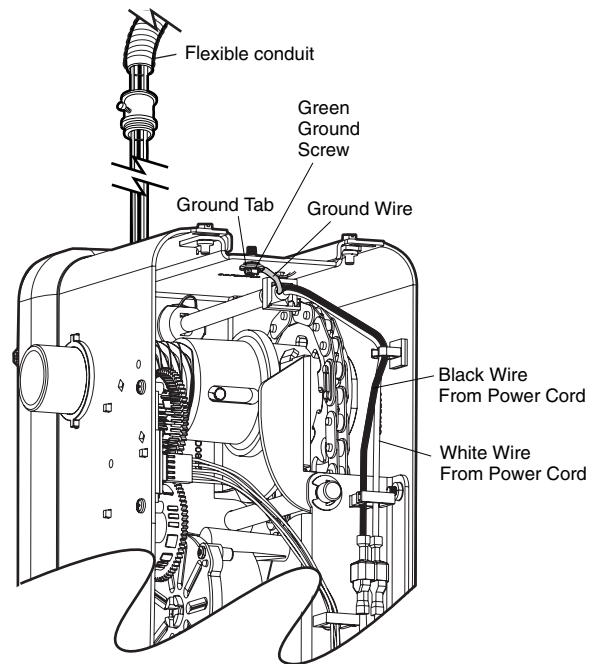

PERMANENT WIRING CONNECTION

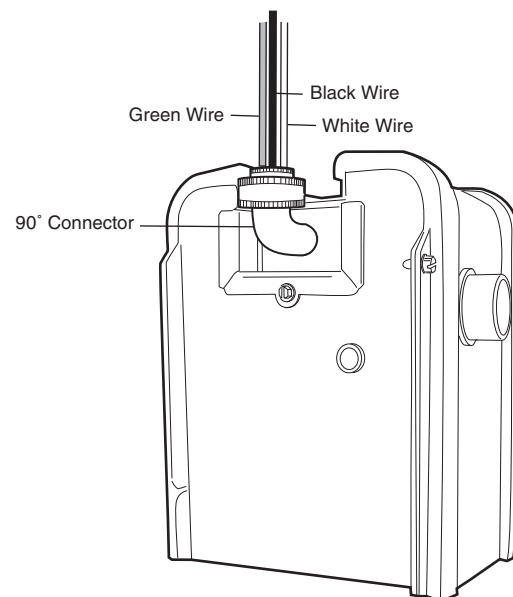

INSTALLATION STEP 8

Mount the Standby Power Unit (SPU) (Not Provided)

If the optional 475LM Standby Power Unit is part of this installation it should be installed at this time.

- The SPU can be mounted to either the ceiling or a wall within 3' (.9 m) of the motor unit.
- Position the SPU as desired to a structural support (ceiling joist or wall stud).
- Attach the SPU to the support using the mounting holes on either side of the SPU.
- Secure the SPU using the 1-1/2" lag screws (2) provided with the SPU unit.
- Connect the SPU cord into the connector on the bottom of the motor unit.
- Follow all instructions included with the 475LM unit to test for proper operation and testing of the SPU.

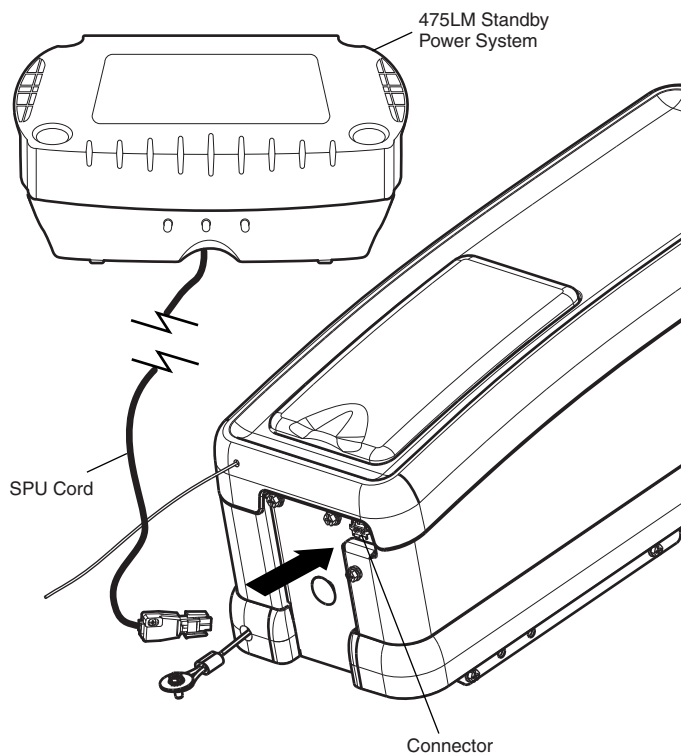

INSTALLATION STEP 7

Install The Protector System®

The safety reversing sensor *must* be connected and aligned correctly before the door operator will move in the down direction. This is a required safety device and cannot be disabled.

IMPORTANT INFORMATION ABOUT THE SAFETY REVERSING SENSOR

When properly connected and aligned, the safety reversing sensor will detect an obstacle in the path of its electronic beam. The sending eye (with an amber indicator light) transmits an invisible light beam to the receiving eye (with a green indicator light). If an obstruction breaks the light beam while the door is closing, the door will stop and reverse to full open position, and the operator lights will flash 10 times.

The units must be installed inside the building so that the sending and receiving eyes face each other across the door, no more than 6" (15 cm) above the floor. Either can be installed on the left or right of the door as long as the sun never shines directly into the receiving eye lens.

The mounting brackets are designed to clip onto the track of sectional doors without additional hardware.

⚠ WARNING

Be sure power is not connected to the door operator BEFORE installing the safety reversing sensor.

To prevent SERIOUS INJURY or DEATH from a closing door:

- Correctly connect and align the safety reversing sensor. This required safety device **MUST NOT** be disabled.
- Install the safety reversing sensor so beam is **NO HIGHER** than 6" (15 cm) above floor.

If it is necessary to mount the units on the wall, the brackets must be securely fastened to a solid surface such as the wall framing. Extension brackets (see accessories) are available if needed. If installing in masonry construction, add a piece of wood at each location to avoid drilling extra holes in masonry if repositioning is necessary.

The invisible light beam path must be unobstructed. No part of the door (door tracks, springs, hinges, rollers or other hardware) may interrupt the beam while the door is closing.

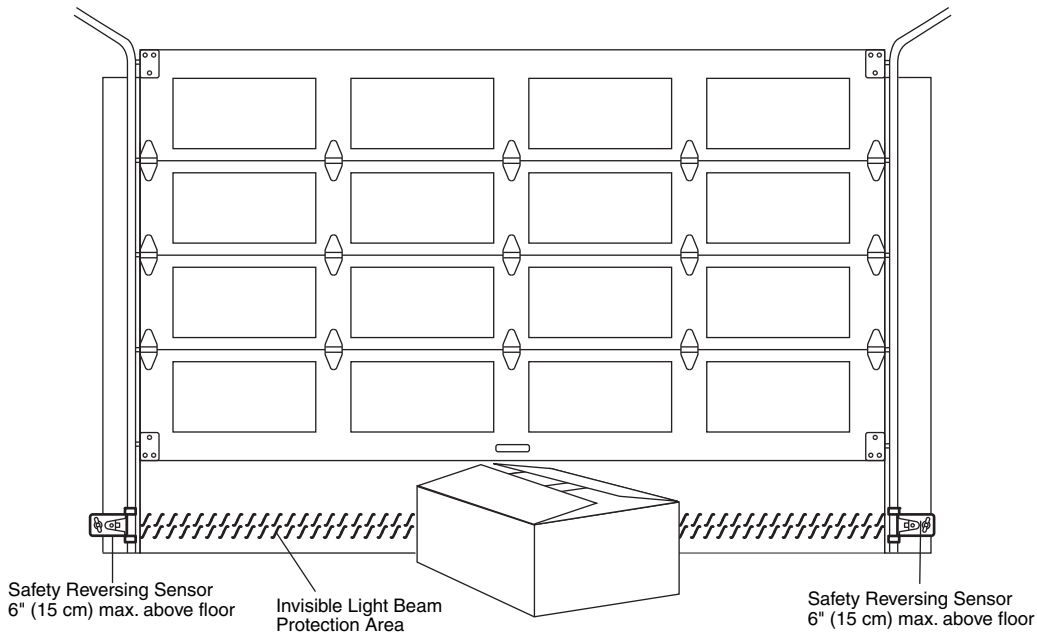

Facing the door from inside the garage

INSTALLING THE BRACKETS

Be sure power to the operator is disconnected. Install and align the brackets so the safety reversing sensors will face each other across the door, with the beam no higher than 6" (15 cm) above the floor. They may be installed in one of three ways, as follows.

Door track installation (preferred) (Figure 1):

- Slip the curved arms over the rounded edge of each door track, with the curved arms facing the door. Snap into place against the side of the track. It should lie flush, with the lip hugging the back edge of the track, as shown in Figure 1.

If your door track will not support the bracket securely, wall installation is recommended.

Wall installation (Figure 2 and 3):

- Place the bracket against the wall with curved arms facing the door. Be sure there is enough clearance for the sensor beam to be unobstructed.
- If additional depth is needed, an extension bracket (See Accessories) or wood blocks can be used.
- Use bracket mounting holes as a template to locate and drill (2) 3/16" diameter pilot holes on the wall at each side of the door, no higher than 6" (15 cm) above the floor.
- Attach brackets to wall with lag screws (Not provided).
- If using extension brackets or wood blocks, adjust right and left assemblies to the same distance out from the mounting surface. Make sure all door hardware obstructions are cleared.

Floor installation (Figure 4):

- Use wood blocks or extension brackets (See Accessories) to elevate sensor brackets so the lenses will be no higher than 6" (15 cm) above the floor.
- Carefully measure and place right and left assemblies at the same distance out from the wall. Be sure all door hardware obstructions are cleared.
- Fasten to the floor with concrete anchors as shown.

Figure 1 DOOR TRACK MOUNT (RIGHT SIDE)

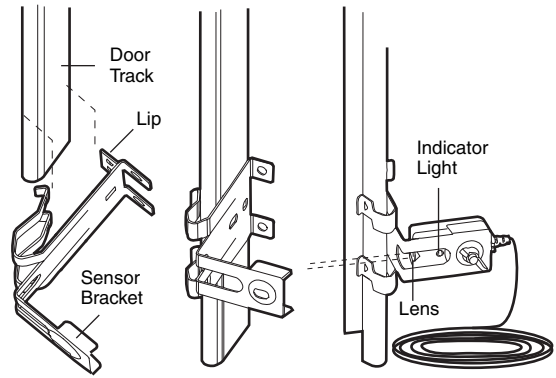

Figure 2 WALL MOUNT (RIGHT SIDE)
Fasten Wood Block to Wall with Lag Screws (Not Provided)

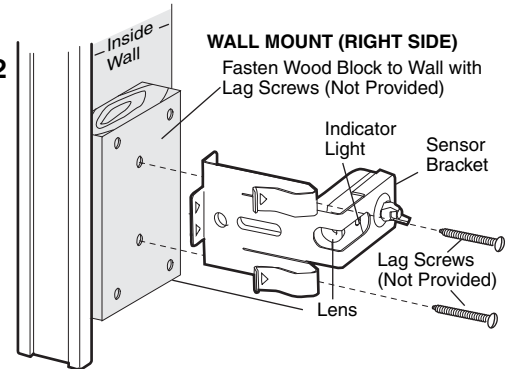

Figure 3 WALL MOUNT (RIGHT SIDE)

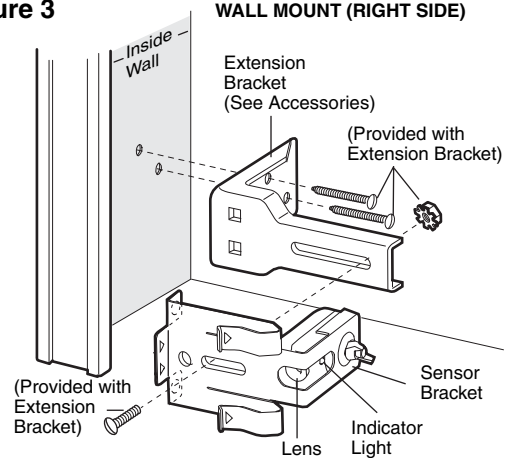
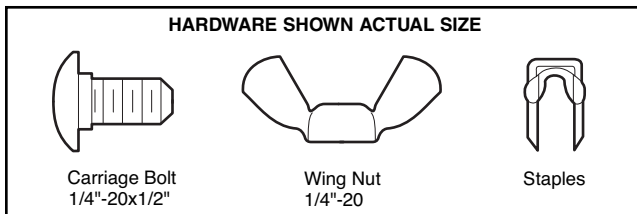
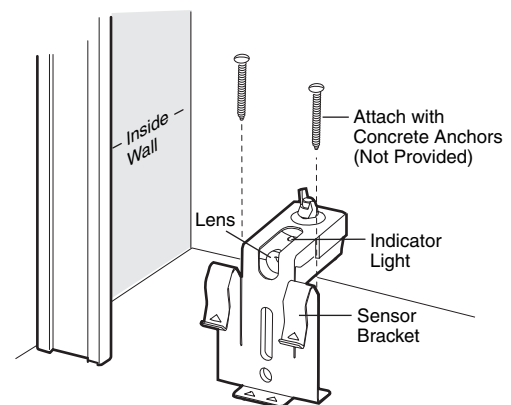

Figure 4 FLOOR MOUNT (RIGHT SIDE)



MOUNTING AND WIRING THE SAFETY REVERSING SENSORS

- Slide a 1/4"-20x1/2" carriage bolt head into the slot on each sensor. Use wing nuts to fasten safety reversing sensors to brackets, with lenses pointing toward each other across the door. Be sure the lens is not obstructed by a bracket extension (Figure 5).
- Finger tighten the wing nuts.
- Run the wires from both safety reversing sensors to the operator. Use insulated staples to secure wire to wall and ceiling.
- Strip 7/16" (11 mm) of insulation from each set of wires. Separate white and white/black wires sufficiently to connect to the operator quick-connect terminals: white to white and white/black to grey (Figure 6).

ALIGNING THE SAFETY REVERSING SENSORS

- Plug in the operator. The indicator lights in both the sending and receiving eyes will *glow steadily* if wiring connections and alignment are correct.
- The *sending eye* amber indicator light will glow regardless of alignment or obstruction. If the green indicator light in the *receiving eye* is off, dim, or flickering (and the invisible light beam path is not obstructed), alignment is required.
- Loosen the *sending eye* wing nut and readjust, aiming directly at the *receiving eye*. Lock in place.
 - Loosen the *receiving eye* wing nut and adjust the safety reversing sensor until it receives the sender's beam. When the green indicator light *glows steadily*, tighten the wing nut.

Figure 5

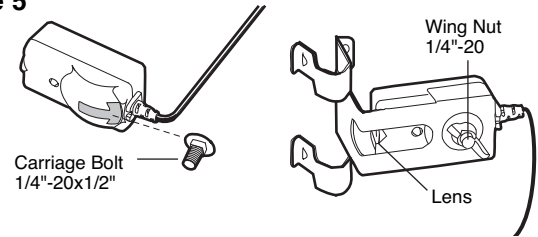

TROUBLESHOOTING THE SAFETY REVERSING SENSORS

1. If the *sending eye* indicator light does not *glow steadily* after installation, check for:
 - Electric power to the operator.
 - A short in the white or white/black wires. These can occur at staples, or at operator connections.
 - Incorrect wiring between safety reversing sensors and operator.
 - A broken wire.
2. If the *sending eye* indicator light *glows steadily* but the *receiving eye* indicator light doesn't:
 - Check alignment.
 - Check for an open wire to the *receiving eye*.
3. If the *receiving eye* indicator light is dim, realign either sensor.

NOTE: When the invisible beam path is obstructed or misaligned while the door is closing, the door will reverse. If the door is already open, it will not close.

Figure 6

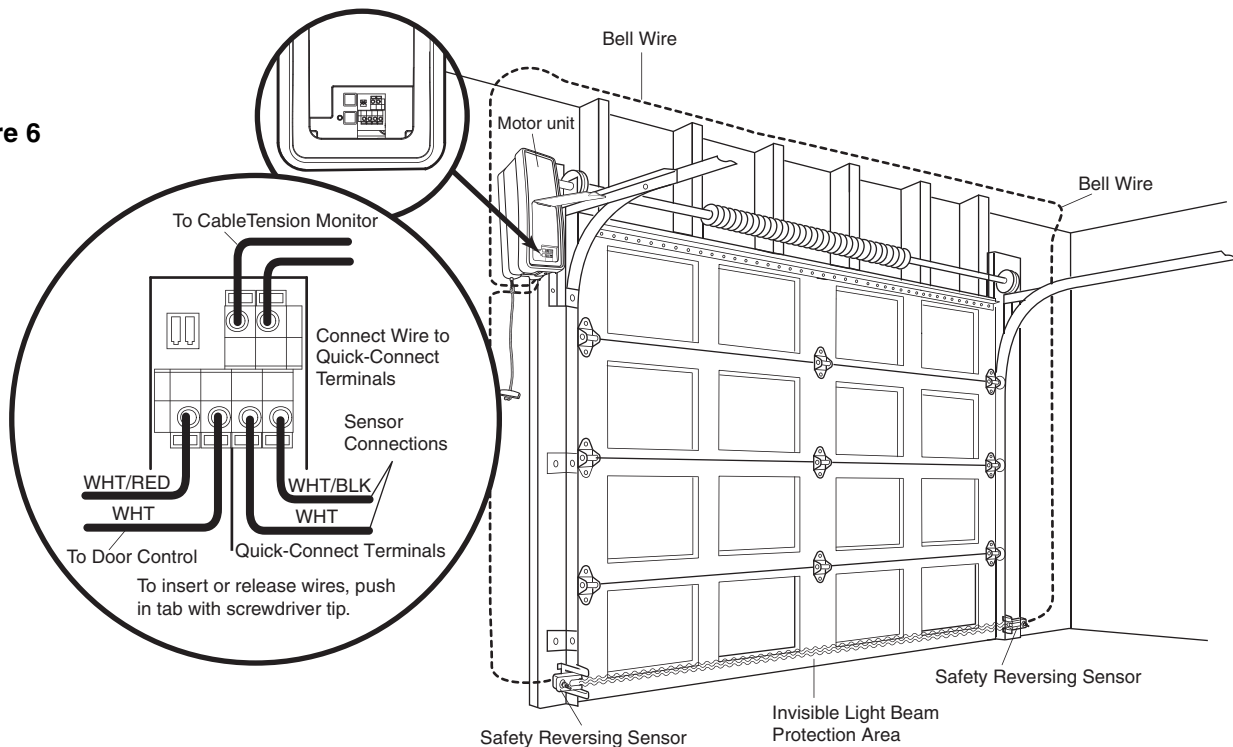

ADJUSTMENT STEP 1

Program the Travel Limits

Travel limits regulate the points at which the door will stop when moving up or down. Follow the steps below to set the limits.

Figure 1

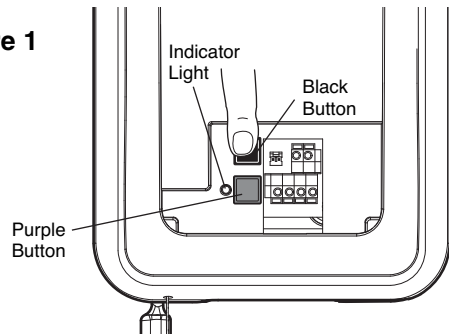

To program the travel limits:

Adjust the position of the door by using the black and purple buttons. Black moves the door UP (open) and purple moves the door DOWN (close).

1. **Setting the UP position:** Press and hold the black button until the yellow indicator light starts flashing slowly then release.
2. Push and hold the black button until the door reaches the desired UP (open) position (Figure 2).

NOTE: Check to be sure the door opens high enough for your vehicle.

3. Push the Single Button Control Station (Figure 3). This sets the UP (open) limit and begins closing the door.

NOTE: Excessive movement of the motor unit will cause premature wear. See Troubleshooting section.

4. Immediately when the door begins to move down, press and release either the black or purple button. This will stop the door.
5. **Setting the DOWN position:** Push and hold the purple button until the door reaches the desired DOWN (closed) position (Figure 4).
6. Once the door is closed, check for proper pressure on the door (you should be able to manually push the door down a 1/16 of an inch). If there appears to be too much pressure on the door, you may toggle the door back and forth using the black and purple buttons to reach the desired position.
7. Push the Single Button Control Station (Figure 3). This sets the DOWN (close) limit and should bring the door to the open position.
 - If the operator is not stopping exactly where you would like it, repeat steps 1 through 7 and program the limits again.
 - When the unit stops in both the desired up (open) and down (close) positions, proceed to *Adjustment Step 2, Setting the Force*.

WARNING

Without a properly installed safety reversal system, persons (particularly small children) could be SERIOUSLY INJURED or KILLED by a closing door.

- NEVER learn forces or limits when door is binding or sticking. Repair door first.
- Incorrect adjustment of door travel limits will interfere with proper operation of safety reversal system.
- After ANY adjustments are made, the safety reversal system MUST be tested. Door MUST reverse on contact with 1-1/2" high (3.8 cm) object (or 2x4 laid flat) on floor.

CAUTION

To prevent damage to vehicles, be sure fully open door provides adequate clearance.

Figure 2

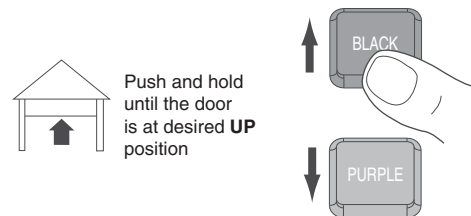

Figure 3

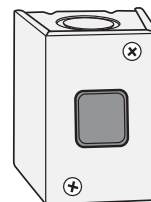
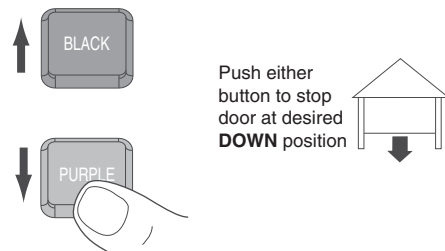

Figure 4



ADJUSTMENT STEP 2

Setting the Force

The force setting button is located on the front panel. The force setting measures the amount of force required to open and close the door.

1. Locate the purple button on the unit (Figure 1).
2. Push the purple button twice to enter unit into Force Adjustment Mode (Figure 2). The LED (Indicator Light) will flash quickly.
3. Push the Single Button Control Station (Figure 3). The door will travel to the DOWN (close) position. Push the Single Button Control Station again, the door will travel to the UP (open) position. Push Single Button Control Station a third time to send the door to the DOWN (close) position.

The LED (Indicator Light) will stop flashing when the force has been learned.

The unit has learned the forces required to open and close your door.

The door must travel through a complete cycle, UP and DOWN, in order for the force to be set properly. If the unit cannot open and close your door fully, inspect your door to insure that it is balanced properly and is not sticking or binding. See page 4, "Preparing your door."

⚠ WARNING

Without a properly installed safety reversal system, persons (particularly small children) could be SERIOUSLY INJURED or KILLED by a closing door.

- NEVER learn forces or limits when door is binding or sticking. Repair door first
- Too much force on door will interfere with proper operation of safety reversal system.
- After ANY adjustments are made, the safety reversal system MUST be tested. Door MUST reverse on contact with 1-1/2" high (3.8 cm) object (or 2x4 laid flat) on floor.

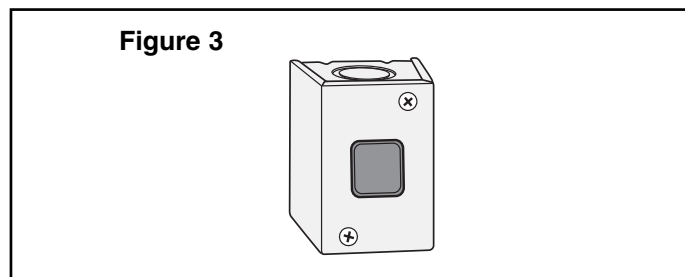
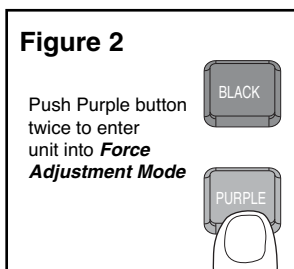
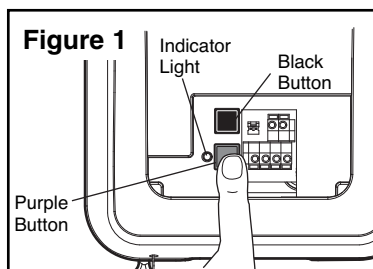

ADJUSTMENT STEP 3

Test the Safety Reversal System

TEST

- With the door fully open, place a 1-1/2" (3.8 cm) board (or a 2x4 laid flat) on the floor, centered under the door.
- Operate the door in the down direction. The door **must** reverse on striking the obstruction. Upon successful safety reversal test proceed to *Adjustment Step 4*.

ADJUST

- If the door stops on the obstruction, it is not traveling far enough in the down direction. Complete Adjustment Steps 1 and 2 Programming the Limits and Forces.
- Repeat the test.
- When the door reverses on the 1-1/2" (3.8 cm) board (or 2x4 laid flat), remove the obstruction and run the operator through 3 or 4 complete travel cycles to test adjustment.
- If the unit continues to fail the Safety Reverse Test, call for a trained door systems technician.

IMPORTANT SAFETY CHECK:

Test the Safety Reverse System after:

- Each adjustment of limits, or force controls.
- Any repair to or adjustment of the door (including springs and hardware).
- Any repair to or buckling of the floor.
- Any repair to or adjustment of the operator.

ADJUSTMENT STEP 4

Test The Protector System®

- Press the remote control push button to open the door.
- Place the operator carton in the path of the door.
- Press the remote control push button to close the door. The door will not move more than an inch, and the operator lights will flash.

The door operator will not close from a remote if the indicator light in either sensor is off (alerting you to the fact that the sensor is misaligned or obstructed).

If the operator closes the door when the safety reversing sensor is obstructed, do not operate the door. Call for a trained door systems technician.

⚠ WARNING

Without a properly installed safety reversal system, persons (particularly small children) could be **SERIOUSLY INJURED** or **KILLED** by a closing door.

- Safety reversal system **MUST** be tested every month.
- If one control (force or travel limits) is adjusted, the other control may also need adjustment.
- After **ANY** adjustments are made, the safety reversal system **MUST** be tested. Door **MUST** reverse on contact with 1-1/2" (3.8 cm) high object (or 2x4 laid flat) on the floor.

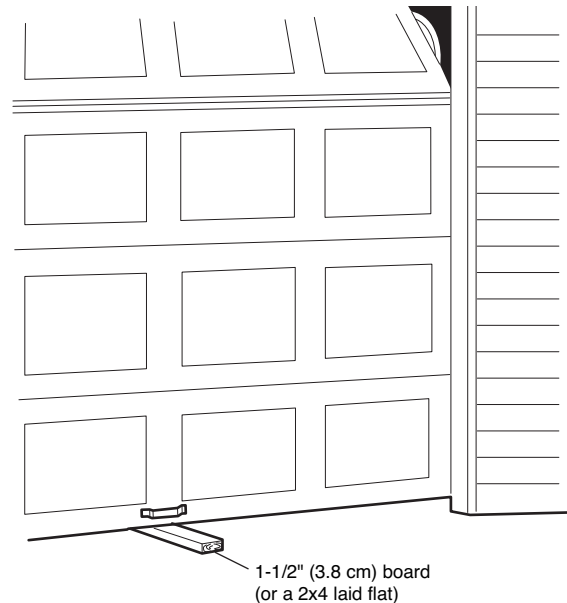

⚠ WARNING

Without a properly installed safety reversing sensor, persons (particularly small children) could be **SERIOUSLY INJURED** or **KILLED** by a closing door.

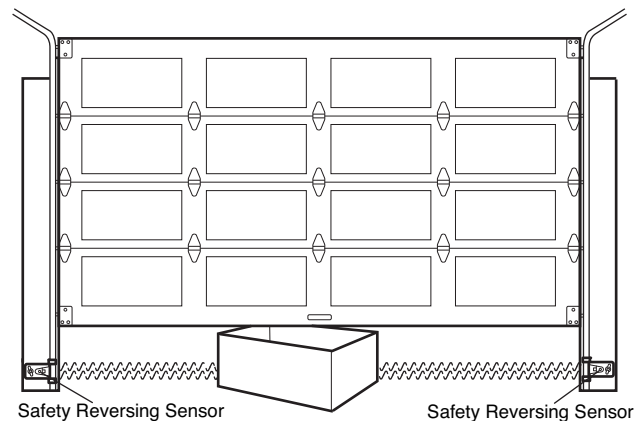

ADJUSTMENT STEP 5

Test Cable Tension Monitor

If your cable tension monitor has been activated the Indicator Light will blink 9 times. See (Figure 1) page 16.

ADJUSTMENT STEP 6

To Open the Door Manually

The door should be fully closed if possible. Pull down on the emergency release handle until a click noise is heard from the unit and lift the door manually. To reconnect the door to the operator, pull down the emergency release handle straight down a second time until a click noise is heard from the unit. The door will reconnect on the next UP or DOWN operation.

Test the emergency release:

- Make sure the door is closed.
- Pull the emergency release handle. The door should then be able to be opened manually.
- Return the door to the closed position.
- Pull the emergency handle a second time.
- Reconnect the door to the operator.

⚠ WARNING

To prevent possible SERIOUS INJURY or DEATH from a falling door:

- If possible, use emergency release handle to disengage door ONLY when door is CLOSED. Weak or broken springs or unbalanced door could result in an open door falling rapidly and/or unexpectedly.
- NEVER use emergency release handle unless doorway is clear of persons and obstructions.

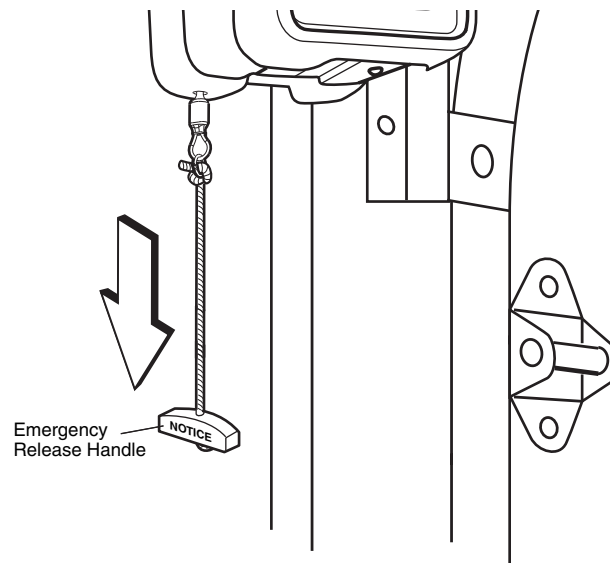

OPERATION

IMPORTANT SAFETY INSTRUCTIONS

WARNING

To reduce the risk of SEVERE INJURY or DEATH:

1. READ AND FOLLOW ALL WARNINGS AND INSTRUCTIONS.
2. ALWAYS keep remote controls out of reach of children. NEVER permit children to operate or play with door control push buttons or remote controls.
3. ONLY activate door when it can be seen clearly, it is properly adjusted and there are no obstructions to door travel.
4. ALWAYS keep door in sight until completely closed. NO ONE SHOULD CROSS THE PATH OF THE MOVING DOOR.
5. NO ONE SHOULD GO UNDER A STOPPED, PARTIALLY OPENED DOOR.
6. If possible, use emergency release handle to disengage door ONLY when door is CLOSED. Weak or broken springs or unbalanced door could result in an open door falling rapidly and/or unexpectedly.
7. NEVER use emergency release handle unless doorway is clear of persons and obstructions.
8. After ANY adjustments are made, the safety reversal system MUST be tested.
9. Safety reversal system MUST be tested every month. Door MUST reverse on contact with 1-1/2" (3.8 cm) high object (or a 2x4 laid flat) on the floor.
10. ALWAYS KEEP DOOR PROPERLY BALANCED (see page 3). An improperly balanced door may not reverse when required and could result in SEVERE INJURY or DEATH.
11. ALL repairs to cables, spring assemblies and other hardware, ALL of which are under EXTREME tension, MUST be made by a trained door systems technician.
12. ALWAYS disconnect electric power to door operator BEFORE making ANY repairs or removing covers.
13. **SAVE THESE INSTRUCTIONS.**

Using Your Door Operator

Press and hold the push button on the Single Button Control Station until the door starts to move.

When the operator is activated (with the safety reversing sensor correctly installed and aligned)

1. If open, the door will close. If closed, it will open.
2. If closing, the door will reverse.
3. If opening, the door will stop.
4. If the door has been stopped in a partially open position, it will close.
5. If obstructed while closing, the door will reverse. If the obstruction interrupts the sensor beam, the operator lights will blink for five seconds.
6. If obstructed while opening, the door will stop.
7. If fully open, the door will not close when the beam is broken. The sensor has no effect in the opening cycle.

CARE OF YOUR OPERATOR

MAINTENANCE SCHEDULE

Once a Month

- Manually operate door. If it is unbalanced or binding, call a trained door systems technician.
- Check to be sure door opens & closes fully. Adjust limits and/or force if necessary (see Adjustment Steps 1 and 2).
- Repeat the safety reverse test. Make any necessary adjustments (see Adjustment Step 3).

Once a Year

- Oil door rollers, bearings and hinges. The operator does not require additional lubrication. Do not grease the door tracks.

HAVING A PROBLEM? (TROUBLESHOOTING)

1. **The operator doesn't operate from either the Door Control or the remote control:**

- Does the operator have electric power? Plug a lamp into the outlet. If it doesn't light, check the fuse box or the circuit breaker. (Some outlets are controlled by a wall switch.)
- Is there a build-up of ice or snow under the door? The door may be frozen to the ground. Remove any restriction.
- The door spring may be broken. Have it replaced (see page 3 for reference).

2. **Operator operates from the remote, but not from the Single Button Control Station:**

- Are the wiring connections correct? Review *Installation Step 5*.

3. **The door operates from the Single Button Control Station, but not from the remote control:**

- Program the operator to match the remote control code. (Refer to instructions on the motor unit panel.) Repeat with all Remotes.

4. **The remote control has short range:**

- Check to be sure the antenna on the side or back panel of operator extends fully downward.
- Some installations may have shorter range due to a metal door, foil backed insulation, or metal siding.

5. **The door opens and closes by itself:**

- Be sure that all remote control push buttons are off.
- Remove the bell wire from the door control terminals and operate from the remote only. If this solves the problem, the single button control station is faulty (replace), or there is an intermittent short on the wire between the control console and the motor unit.
- Clear memory and re-program all remote controls.

6. **The door doesn't open completely:**

- Is something obstructing the door? Is it out of balance, or are the springs broken? Remove the obstruction or repair the door.

7. **The door opens but won't close:**

- Check cable tension monitor (see installation step 4).
- Check the safety reversing sensor. See *Installation Step 9*.
- See *Adjustment Step 2*. For an existing installation, see below.

Repeat the safety reverse test after the adjustment is complete.

8. **The door reverses for no apparent reason:**

- Check cable tension monitor (see installation step 4).
- Is something obstructing the door? Pull the emergency release handle. Operate the door manually. If it is unbalanced or binding, call a trained door systems technician.
- Clear any ice or snow from the floor area where the door closes.
- Review *Adjustment Step 2*.

Repeat safety reverse test after adjustments.

9. **The door reverses for no apparent reason:**

- Check the safety reversing sensor. Remove any obstruction or align the receiving eye. See *Installation Step 9*.

10. **The operator strains to operate door:**

- The door may be out of balance or the springs may be broken. **Close the door** and use the emergency release handle to disconnect the door. Open and close the door manually. A properly balanced door will stay in any point of travel while being supported entirely by its springs. If it does not, disconnect the operator and call a trained door systems technician.

Having a Problem? (Continued)

11. The operator motor hums briefly, then won't work:

- The door springs may be broken. See above.

12. The operator won't operate due to power failure:

- Use the emergency release handle to disconnect the door. The door can be opened and closed manually. When power is restored, pull manual release a second time.
- If a Standby Power Unit is connected, the operator should be able to operate up to 20 times without power.

13. Door loses limits.

- Collar not tightened securely. Tighten collar (see Assembly Steps 1 and 2) and reprogram limits (see Adjustment Step 1).

14. The operator moves when the door is in operation:

- Some minor movement is normal for this product. If it is excessive the collar will wear prematurely.
- Check to make sure the torsion bar is not moving left/right excessively.
- Check to make sure the torsion bar is not visibly moving up and down as it rotates.
- Check that the operator is mounted at a right angle to the jackshaft. If not, move the position of the mounting bracket.

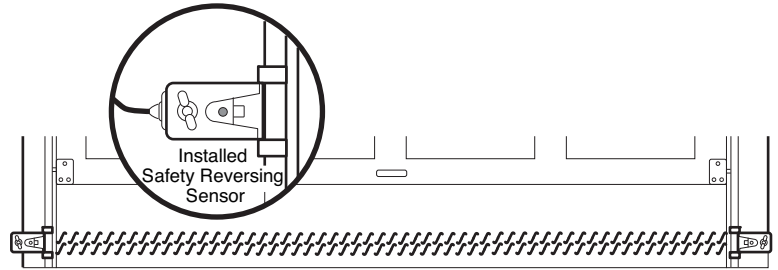
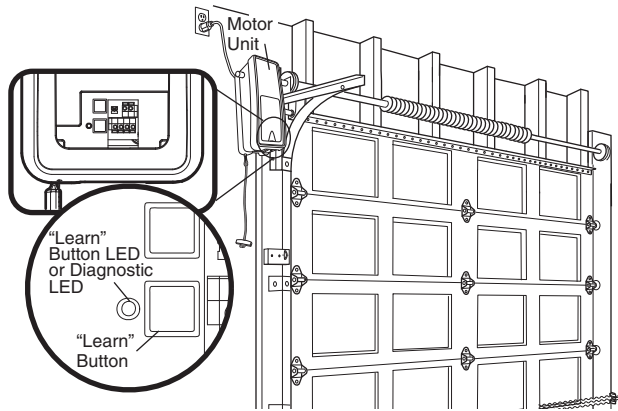

Your garage door operator is programmed with self-diagnostic capabilities. The "Learn" button/diagnostic LED will flash a number of times then pause signifying it has found a potential issue. Consult Diagnostic Chart below.

Diagnostic Chart

1 FLASH

Safety reversing sensors wire open (broken or disconnected).

OR

2 FLASHES

Safety reversing sensors wire shorted or black/white wire reversed.

3 FLASHES

Door control or wire shorted.

4 FLASHES

Safety reversing sensors slightly misaligned (dim or flashing LED).

5 FLASHES

Motor overheated or possible RPM sensor failure. Unplug to reset.

9 FLASHES

Cable tension monitor reversal.

● **Symptom: One or both of the Indicator lights on the safety reversing sensors do not glow steady.**

- Inspect sensor wires for a short (staple in wire), correct wiring polarity (black/white wires reversed), broken or disconnected wires, replace/attach as needed.
- Disconnect all wires from back of motor unit.
- Remove sensors from brackets and shorten sensor wires to 1-2 ft (30-60 cm) from back each of sensor.
- Reattach sending eye to motor unit using shortened wires. If sending eye indicator light glows steadily, attach the receiving eye.
- Align sensors, if the indicator lights glow replace the wires for the sensors. If the sensor indicator lights do not light, replace the safety reversing sensors.

● **Symptom: LED is not lit on door control.**

- Inspect door control/wires for a short (staple in wire), replace as needed.
- Disconnect wires at door control, touch wires together. If motor unit activates, replace door control.
- If motor unit does not activate, disconnect door control wires from motor unit. Momentarily short across red and white terminals with jumper wire. If motor unit activates, replace door control wires.

● **Symptom: Sending indicator light glows steadily, receiving indicator light is dim or flashing.**

- Realign receiving eye sensor, clean lens and secure brackets.
- Verify door track is firmly secured to wall and does not move.

● **Symptom: Motor has overheated; the motor unit does not operate = Motor unit hums briefly; RPM Sensor = Short travel 6-8" (15-20 cm).**

- Unplug unit to reset. Try to operate motor unit, check diagnostic code.
- If it is still flashing 5 times and motor unit moves 6-8" (15-20 cm), replace RPM sensor.
- If motor unit doesn't operate, motor unit is overheated. Wait 30 minutes and retry. If motor unit still will not operate replace logic board.

● **Symptom: Door reverses while closing.**

- Check for possible door obstructions and remove.
- Check that the cable tension monitor is properly connected to the operator.
- Replace the cable tension monitor.

PROGRAMMING

NOTICE: If this Security+® door operator is operated with a non-rolling code transmitter, the technical measure in the receiver of the door operator, which provides security against code-theft devices, will be circumvented. The owner of the copyright in the door operator does not authorize the purchaser or supplier of the non-rolling code transmitter to circumvent that technical measure.

To Add or Program a Hand-held Remote Control (Not Provided)

Below are instructions for programming your operator to operate with optional Security+® remote controls. A maximum of eight Security+® remote controls can be programmed to work with your operator.

USING THE “LEARN” BUTTON

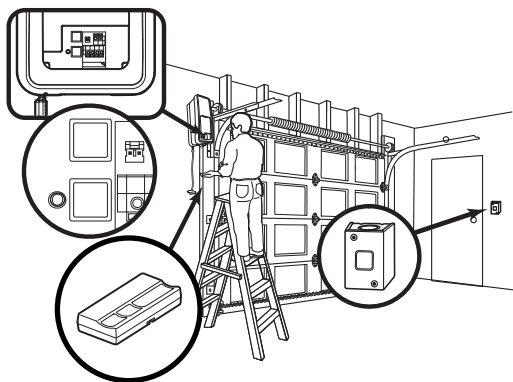

1. Press and release the purple “learn” button on the motor unit. The learn indicator light will glow steadily for 30 seconds.

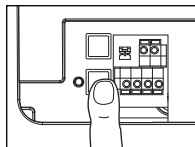

2. Within 30 seconds, press and hold the button on the hand-held remote* that you wish to operate your door.

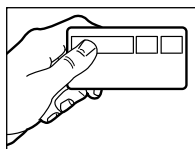

3. Release the button when the learn indicator light blinks and shuts off upon learning the remote control. If the optional remote light is installed, the light will blink.

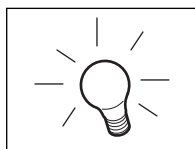

4. If the safety reversing sensors are not installed or misaligned, the door will not close from a hand-held remote control. If this occurs, the door can be closed by pressing and holding the push button on the Single Button Control Station until the door has closed. Releasing the push button prior to the door closing will cause the door to reverse.

To Erase All Codes From Motor Unit Memory

To deactivate any unwanted remote, first erase all codes:

Press and hold the “learn” button on motor unit until the learn indicator light goes out (approximately 6-9 seconds). All previous codes are now erased. Reprogram each remote or keyless entry you wish to use.

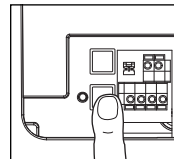

*3-Button Remote

If provided with your door operator, the large button is factory programmed to operate it. Additional buttons on any Security+® 3-Button remote can be programmed to operate other Security+® door operators.

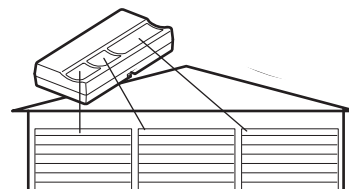

THE REMOTE CONTROL BATTERY

⚠ WARNING

To prevent possible SERIOUS INJURY or DEATH:

- NEVER allow small children near batteries.
- If battery is swallowed, immediately notify doctor.

To reduce risk of fire, explosion or chemical burn:

- Replace ONLY with 3V2032 coin batteries.
- Do NOT recharge, disassemble, heat above 100°C (212°F) or incinerate.

The lithium battery should produce power for up to 5 years.

To replace battery, use the visor clip or screwdriver blade to pry open the case as shown. Insert battery positive side up (+).

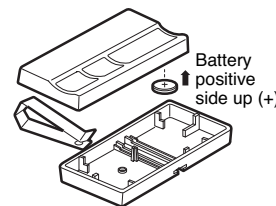

Dispose of old battery properly.

Replace the battery with only 3V2032 coin cell batteries.

NOTICE: To comply with FCC and/or Industry Canada rules (IC), adjustment or modifications of this receiver and/or transmitter are prohibited, except for changing the code setting or replacing the battery. THERE ARE NO OTHER USER SERVICEABLE PARTS.

Tested to Comply with FCC Standards FOR HOME OR OFFICE USE. Operation is subject to the following two conditions: (1) this device may not cause harmful interference, and (2) this device must accept any interference received, including interference that may cause undesired operation.

To Add, Program or Change a Keyless Entry PIN (Not Provided)

NOTE: The optional Keyless Entry must be programmed to operate your garage door operator.

USING THE “LEARN” BUTTON

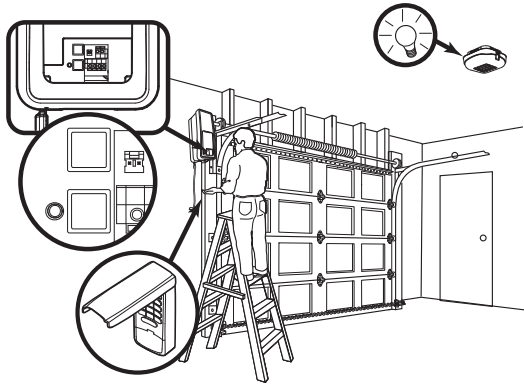

1. Press and release the purple “learn” button on motor unit. The learn indicator light will glow steadily for 30 seconds.

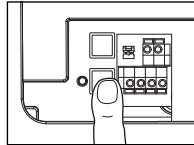

2. Within 30 seconds, enter a four digit personal identification number (PIN) of your choice on the keypad. Then press and hold the ENTER button.

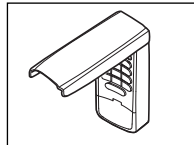

3. Release the button when the learn indicator light blinks and shuts off upon learning the remote control. If the optional remote light is installed, the light will blink.

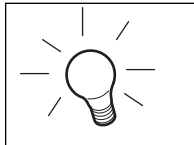

To change an existing, known PIN

If the existing PIN is known, it may be changed by one person without using a ladder.

1. Press the four buttons for the present PIN, then press and hold the # button.

The operator light will blink twice. Release the # button.

2. Press the new 4-digit PIN you have chosen, then press Enter.

The motor unit lights will blink once when the PIN has been learned.

Test by pressing the new PIN, then press Enter. The door should move.

To set a temporary PIN

You may authorize access by visitors or service people with a temporary 4-digit PIN. After a programmed number of hours or number of accesses, this temporary PIN expires and will no longer open the door. It can be used to *close* the door even after it has expired. To set a temporary PIN:

1. Press the four buttons for your personal entry PIN (not the last temporary PIN), then press and hold the * button.

The operator light will blink three times. Release the button.

2. Press the temporary 4-digit PIN you have chosen, then press Enter.

The operator light will blink four times.

3. To set the number of **hours** this temporary PIN will work, press the number of hours (up to 255), then press *.

Programming Remote Light (Not Provided)

The garage door operator remote light will need to be programmed to operate with the door operator. Follow the instructions below to program the light.

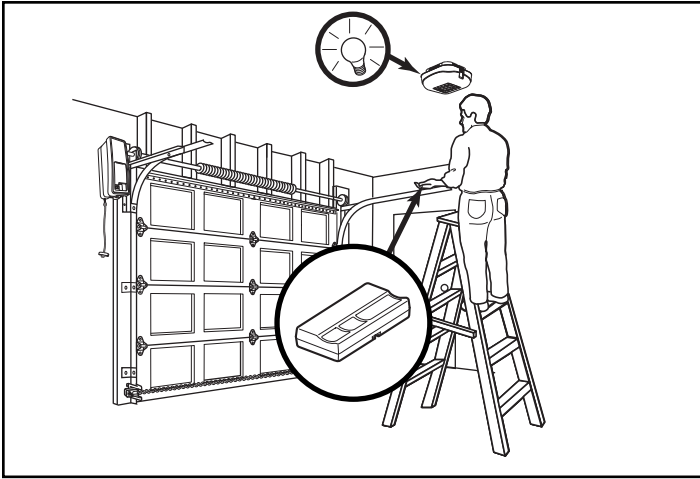

1. Press the “learn button” on light until LED comes ON.

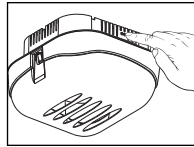

2. Activate the door using the Single Button Control Station (or hand-held remote control or keyless entry, if programmed).

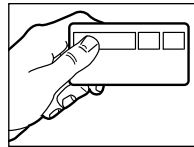

3. It has learned the code and the light turns on.

REPAIR PARTS

Installation Parts

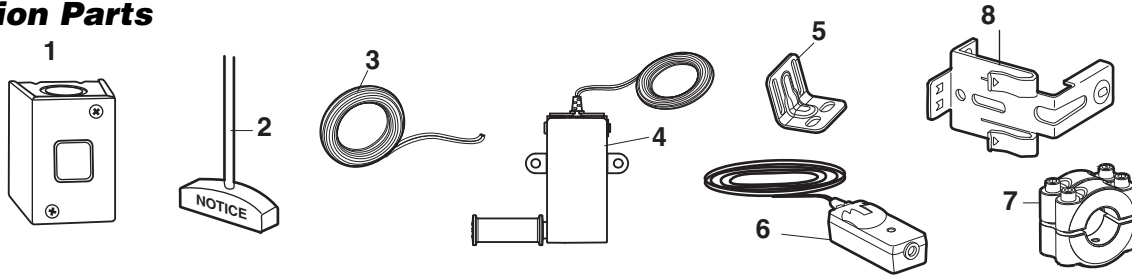

KEY NO.	PART NO.	DESCRIPTION	KEY NO.	PART NO.	DESCRIPTION
1	APBS 1	Single button control station	7	41A6388	Collar with set screws (2)
2	41A4582	Emergency release rope & handle assembly	8	41A5266-1	Safety sensor brackets (2)
3	41B4494-1	2-Conductor bell wire - white & white/red	NOT SHOWN		
4	41A6104	Cable tension monitor		41A6298	Installation hardware bag (includes hardware listed on page 5)
5	41C0902	Mounting bracket		114A3593	Owner's manual
6	41A5034	Safety sensor kit (receiving and sending eyes) with 3' (.9 m) 2-conductor bell wire attached			

Motor Unit Assembly Parts

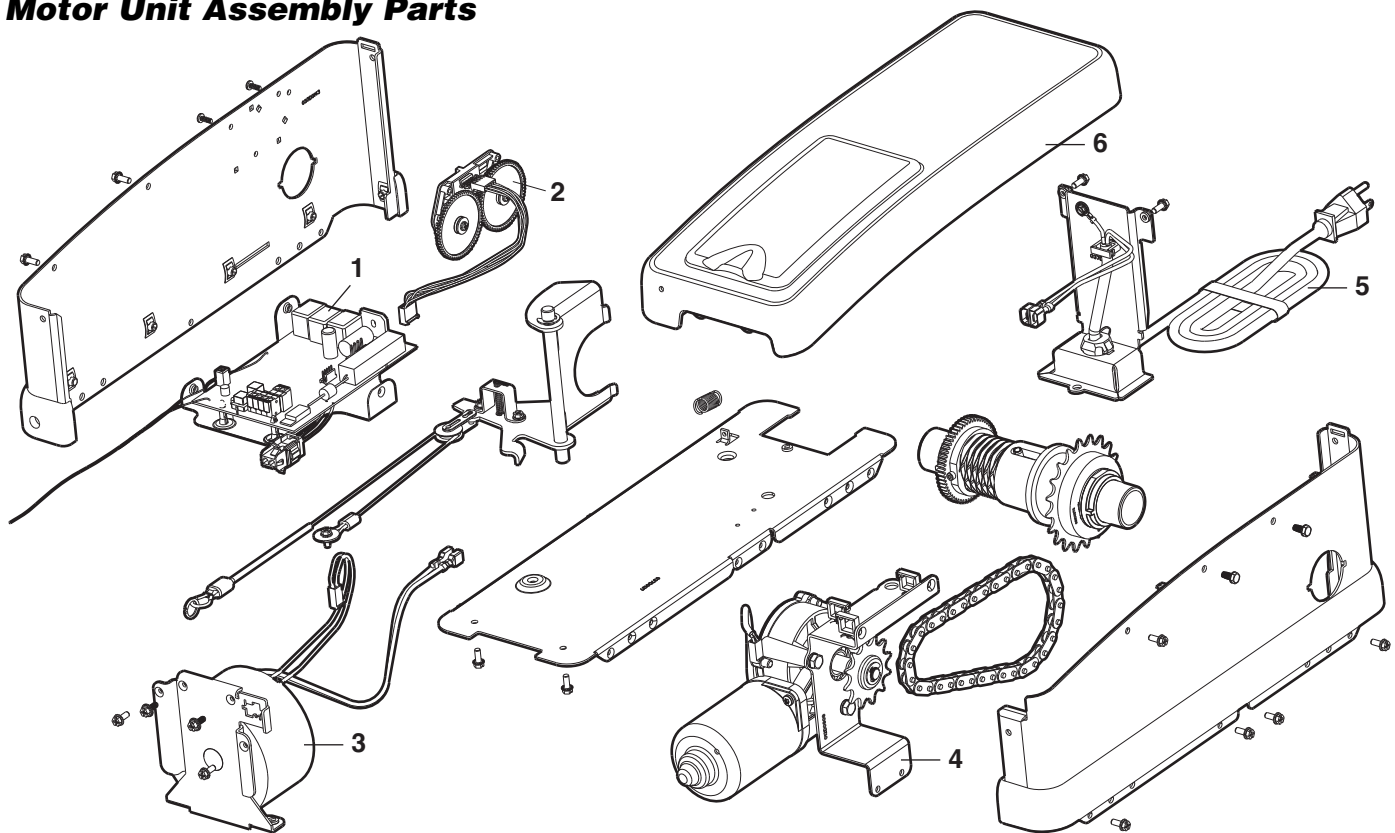

KEY NO.	PART NO.	DESCRIPTION	KEY NO.	PART NO.	DESCRIPTION
1	41DJ001	Logic board complete with plate	4	41A6095	Motor with bracket
2	41A6408	Absolute Encoder System	5	41B122	Power cord
3	41C168	Transformer	6	41A6348-3	Cover

ACCESSORIES

41A5281

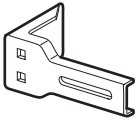

Extension Brackets:

(Optional) For safety reversing sensor installation onto the wall or floor.

377LM

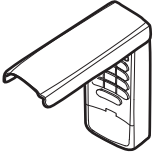

Keyless Entry with Security+®:

Enables end user to operate door operator from outside by entering a password on a specially designed keyboard. Also can add a temporary password for visitors or service persons. This temporary password can be limited to a programmable number of hours or entries.

380LM

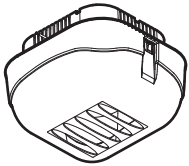

Remote Work Light:

Enables homeowner to turn on a work light from their car with their door operator remote or from anywhere in their home with an additional LiftMaster Security+® remote.

475LM

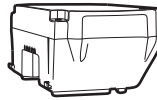

EverCharge™ StandBy Power System:

Provides backup power to the model 3900 door operator.

480LM

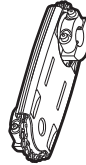

Alternate Mounting Kit:

This kit allows the operator to be mounted below the torsion bar in the case where the torsion bar is not round or the normal mounting area is obstructed.

41A6102

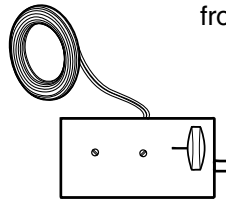

Power Door Lock:

Enables the end user to prevent the door from being manually opened once closed.

LIFTMASTER® SERVICE IS ON CALL

**OUR LARGE SERVICE ORGANIZATION
SPANS AMERICA**

**INSTALLATION AND SERVICE INFORMATION IS AS NEAR
AS YOUR TELEPHONE.
SIMPLY DIAL OUR TOLL FREE NUMBER:**

1-800-528-2806

www.liftmaster.com

For professional installation, parts and service, contact your local LIFTMASTER/CHAMBERLAIN dealer. Look for him in the Yellow Pages, or call our Service number for a list of dealers in your area.

HOW TO ORDER REPAIR PARTS

Selling prices will be furnished on request or parts will be shipped at prevailing prices and you will be billed accordingly.

**WHEN ORDERING REPAIR PARTS, ALWAYS GIVE THE
FOLLOWING INFORMATION:**

- **PART NUMBER**
- **PART NAME**
- **MODEL NUMBER**

ADDRESS ORDERS TO:

THE CHAMBERLAIN GROUP, INC.
Technical Support Group
6050 S. Country Club Road
Tucson, Arizona 85706

SERVICE INFORMATION

TOLL FREE NUMBER:

1-800-528-2806